

# FURNITURE DESIGN

CHRISTIAN JUNAEDI

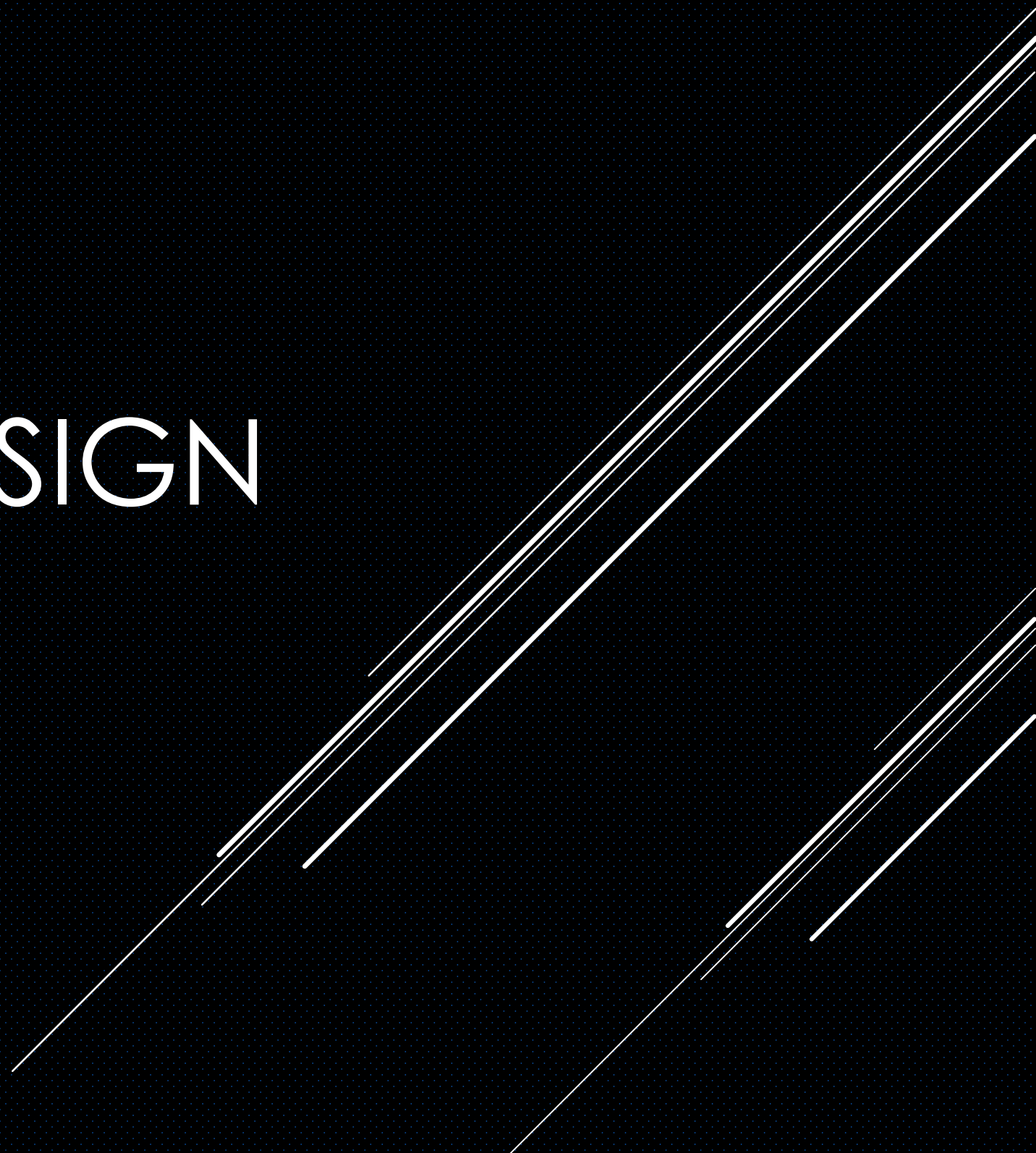

# “ICHI”

- ▶ ICHI IS THE CONCEPT OF TABLES AND CHAIRS THAT BECOME 1 , USING MATERIALS THAT ARE SPECIFICALLY JAPANESE, WHERE THIS TABLE IS SPECIFICALLY FOR EAT IN THE RESTAURANT FOR A DINING AREA FOR 1 PERSON

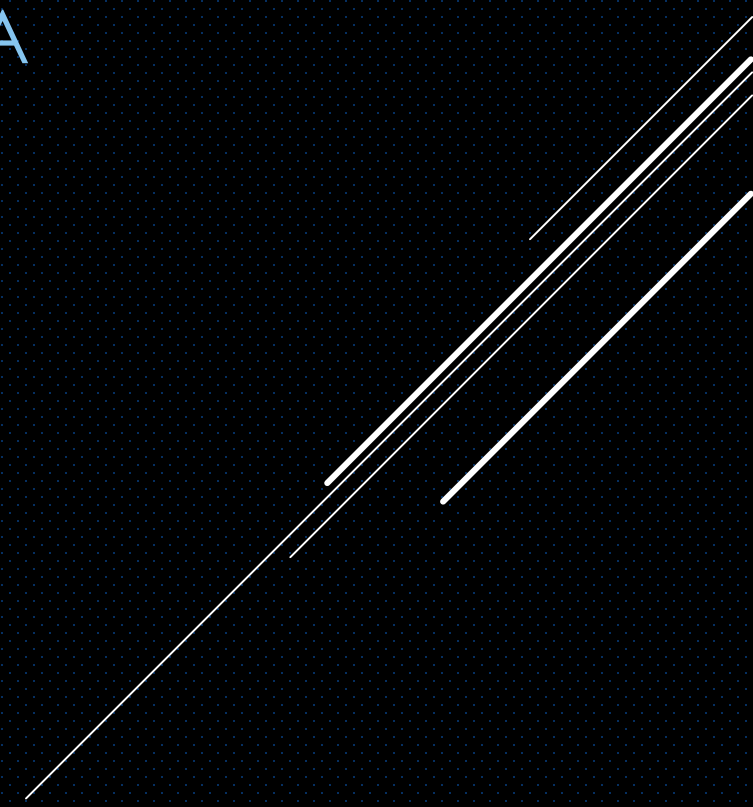

# MATERIAL

- ▶ HPL BAMBOO  
MOTIF ON MDF





- ▶ Bamboo is a common theme in Japanese literature and a favoured subject of painters. Along with the evergreen pine and plum, which is the first flower of spring, bamboo is a part of the traditional Three Friends of Winter. The three are a symbol of steadfastness, perseverance, and resilience. Japanese artists have often represented bamboo enduring inclement weather, such as rain or snow, reflecting its reputation for being flexible but unbreakable, and its association with steadfastness and loyalty.
- ▶ Supplemental usage of bamboo in architecture can include scaffolding, windows, walls, fences, and water pipes such as shishi-odoshi. Items for catching, transporting, and preparing food can include cages, baskets, cooking vessels, rollers, and chopsticks. Items for personal hygiene carved out of bamboo are traditional combs, earpicks, and toothpicks. Personal items such as hats and shoes out of thin strips were made, as well as parasols and fans. Bamboo was also crafted into weapons such as the yumi and arrows, spears, and for martial arts such as the shinai. Bamboo textiles could be woven to be used for ropes and even woven as a fabric. A whole range of musical wind instruments are also crafted out of bamboo, such as the hotchiku, kagurabue, komabue, minteki, nohkan, ryūteki, shakuhachi, shinobue, and yokobue.

▶ PROBLEM : EATING

▶ SOCIAL ISSUE: ILLEGAL LOGGING  
WOOD, AND MANY FURNITURE MADE  
FROM IT



▶ CHALLENGES: FURNITURE FROM MDF/PLYWOOD  
FROM RESPONSIBLE FACTORY , AND RESPONSIBLE  
WOOD FACTORY

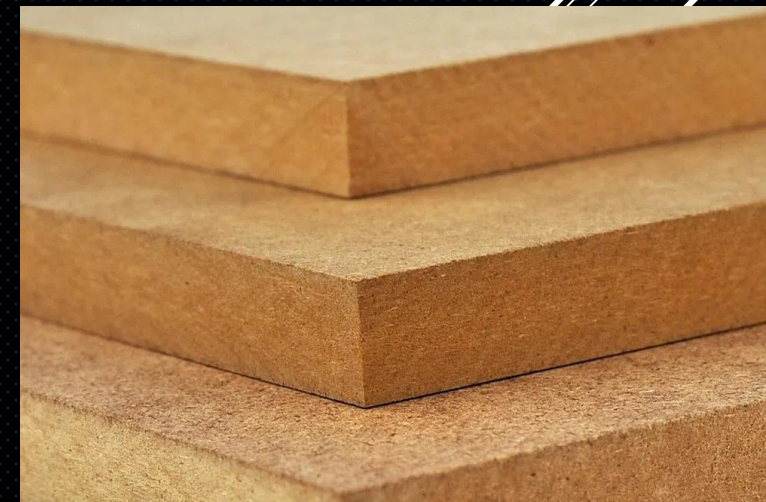



# PRECEDENT CASE

▶ WAGYU



# MIND MAP

SHAPE:  
CURVY

TEXTURE:  
rough, marbling

WAGYU

GEOLOCATION:

JAPAN INFUSE

JAPAN

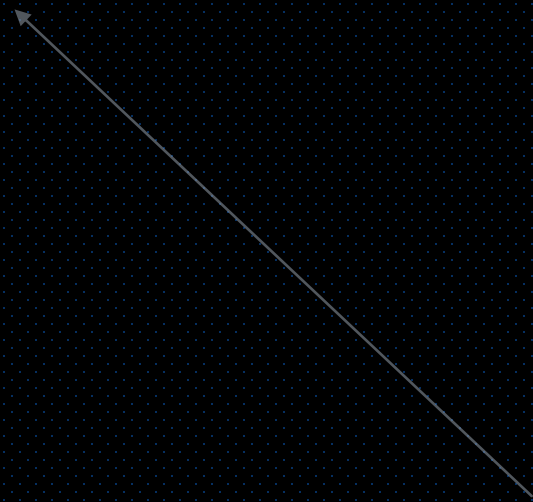

# PATTERN

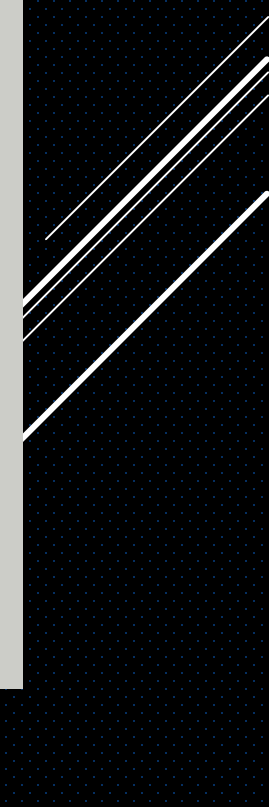
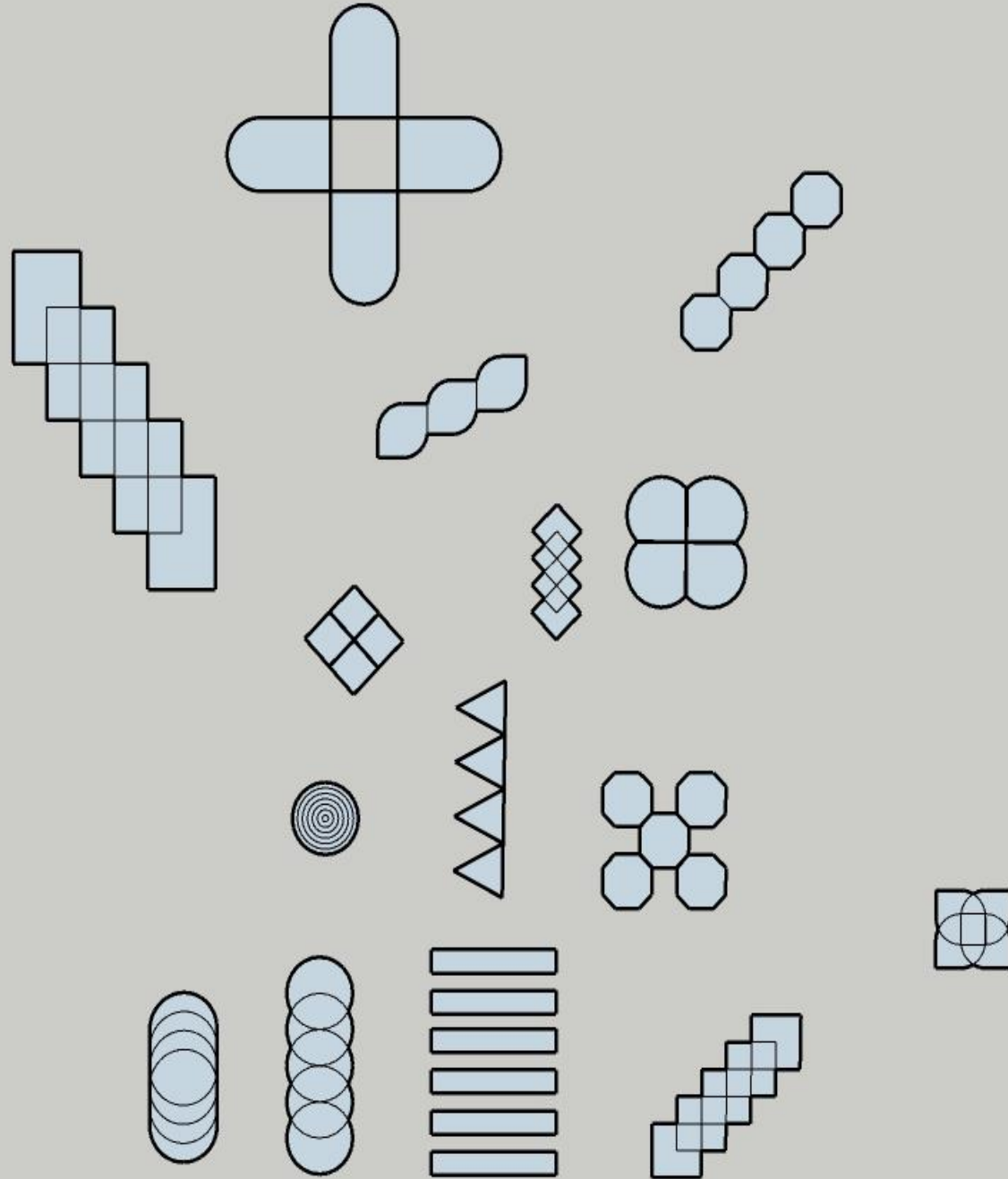



# SHAPE

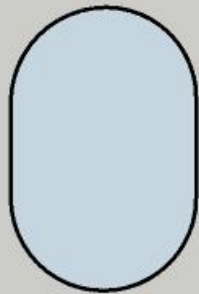
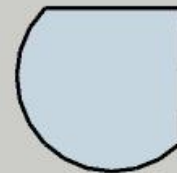
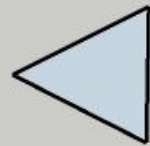
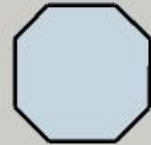
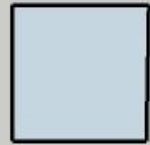
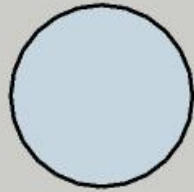
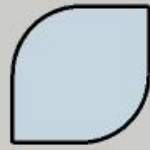
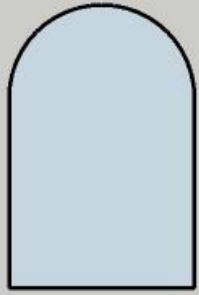

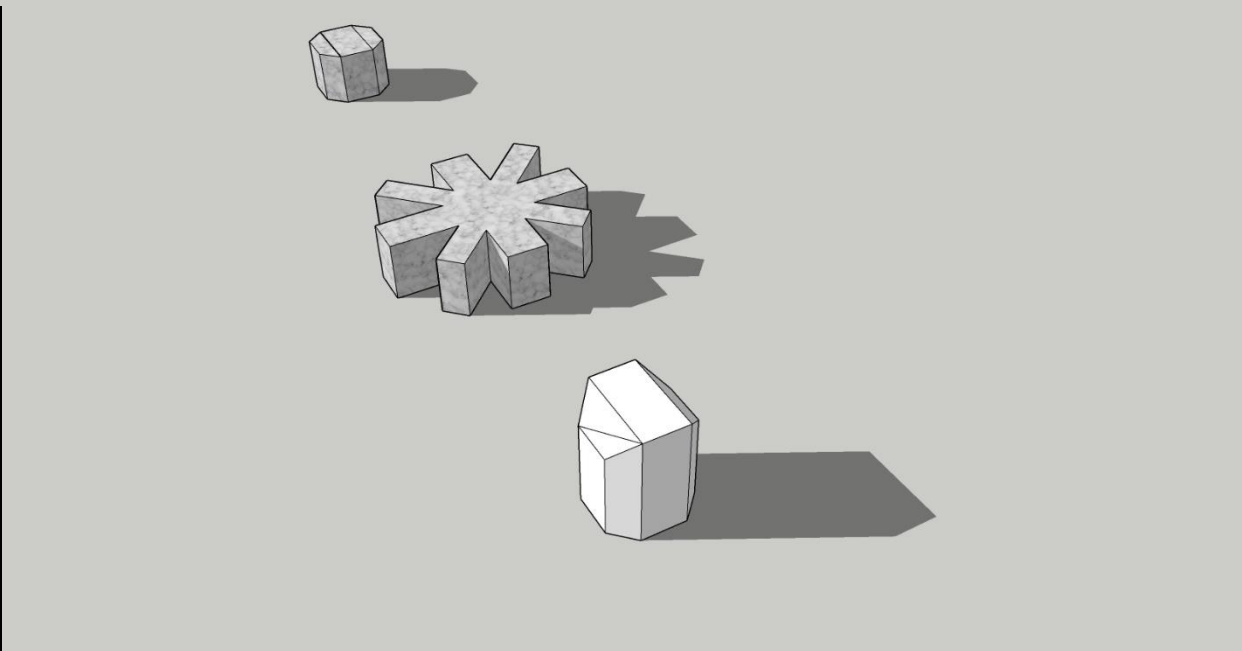
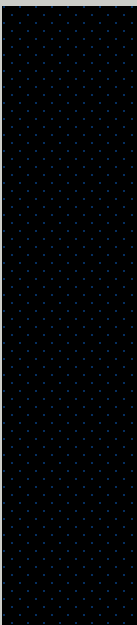
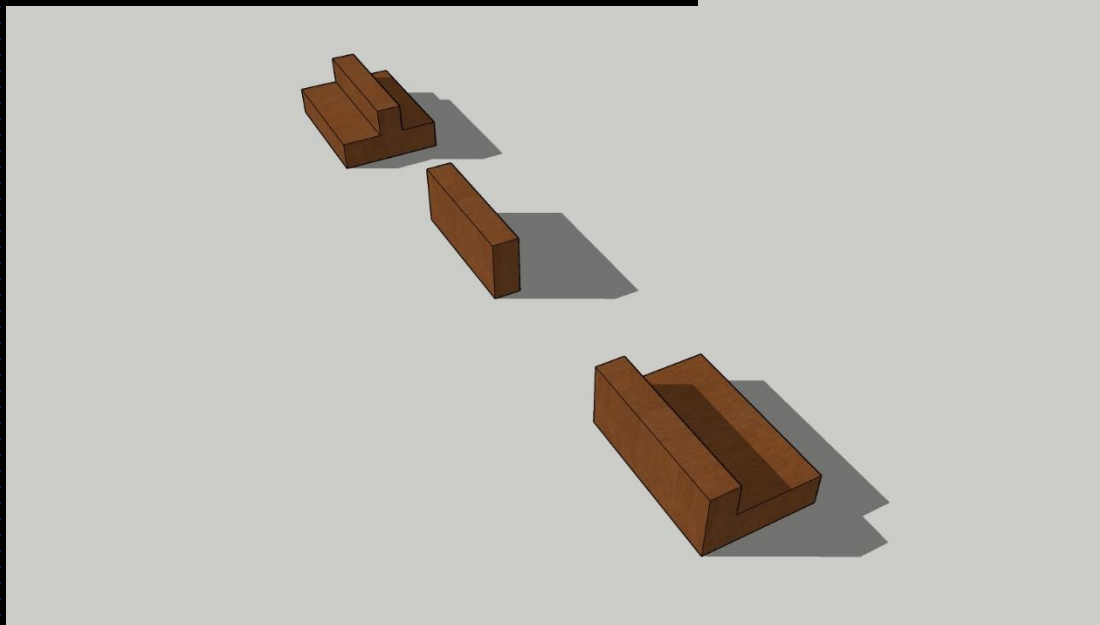
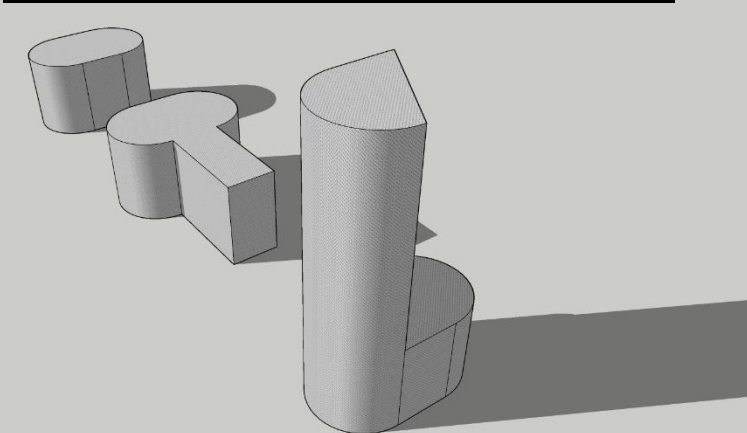
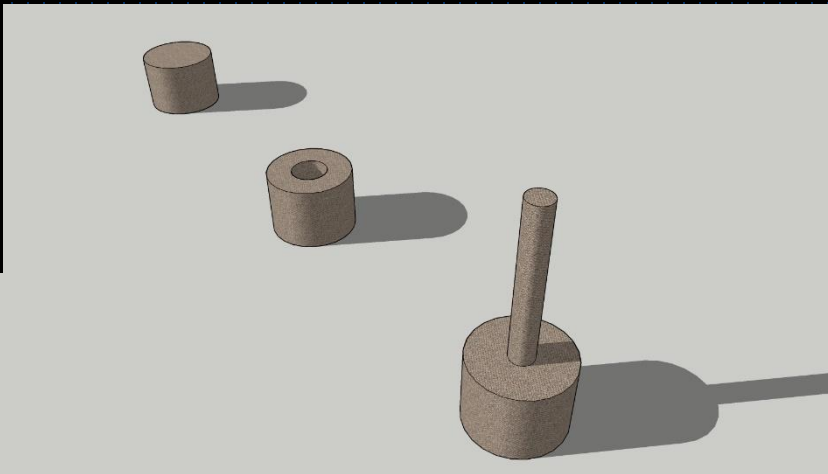
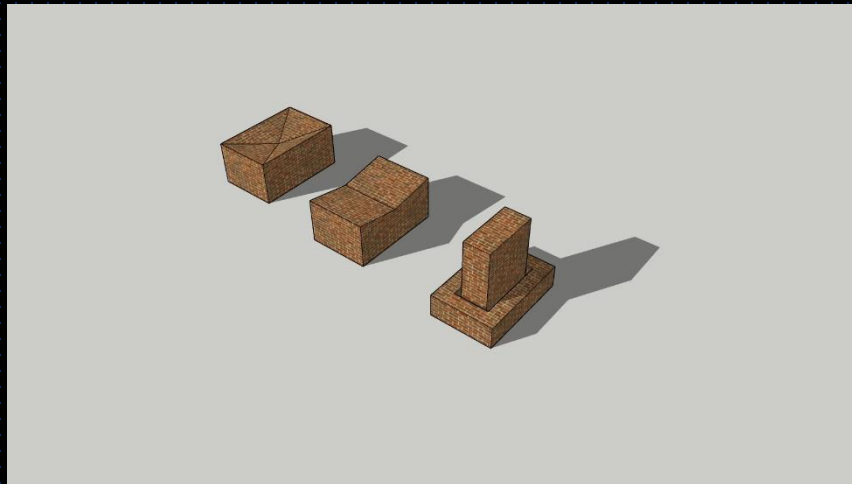

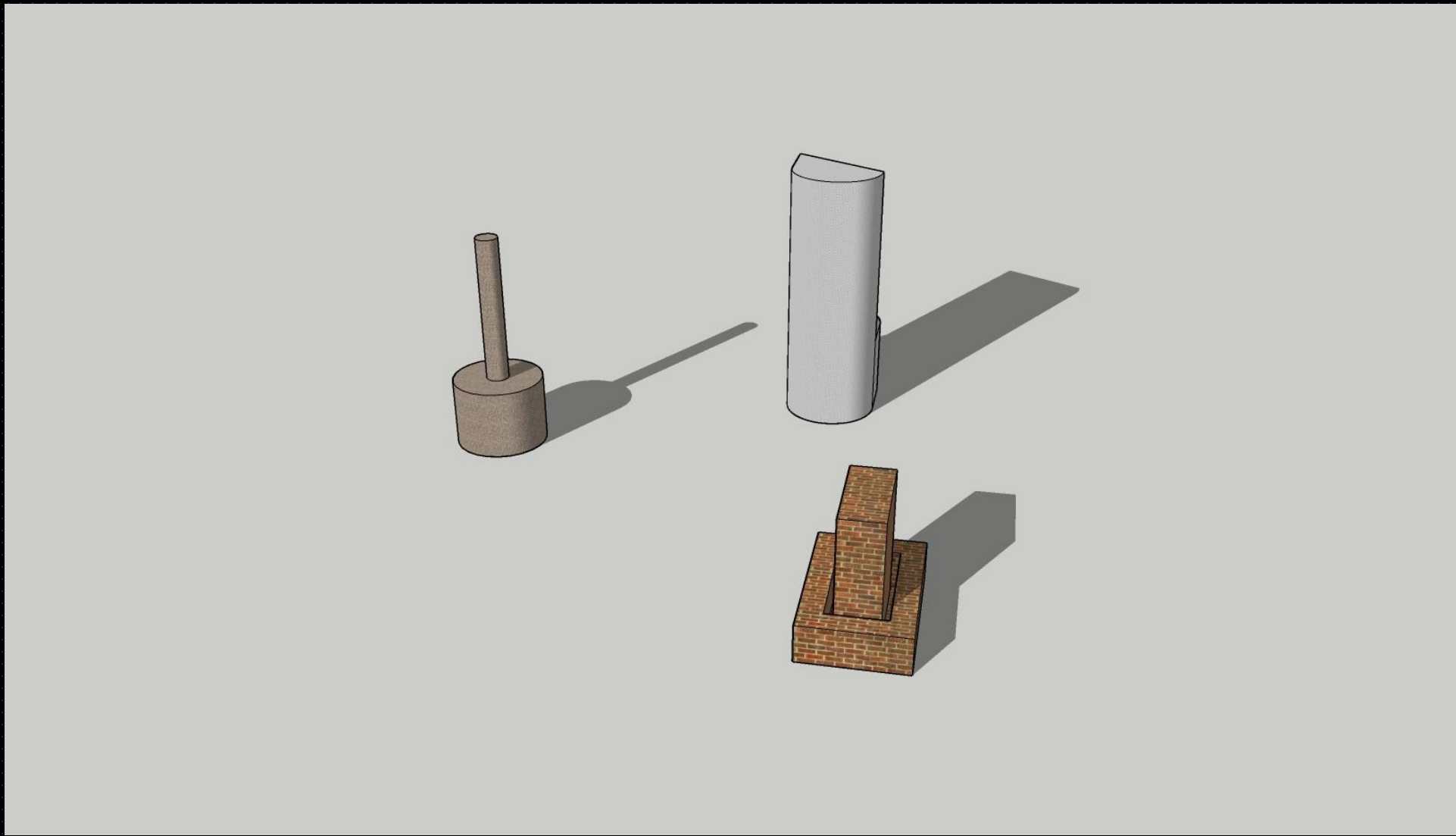



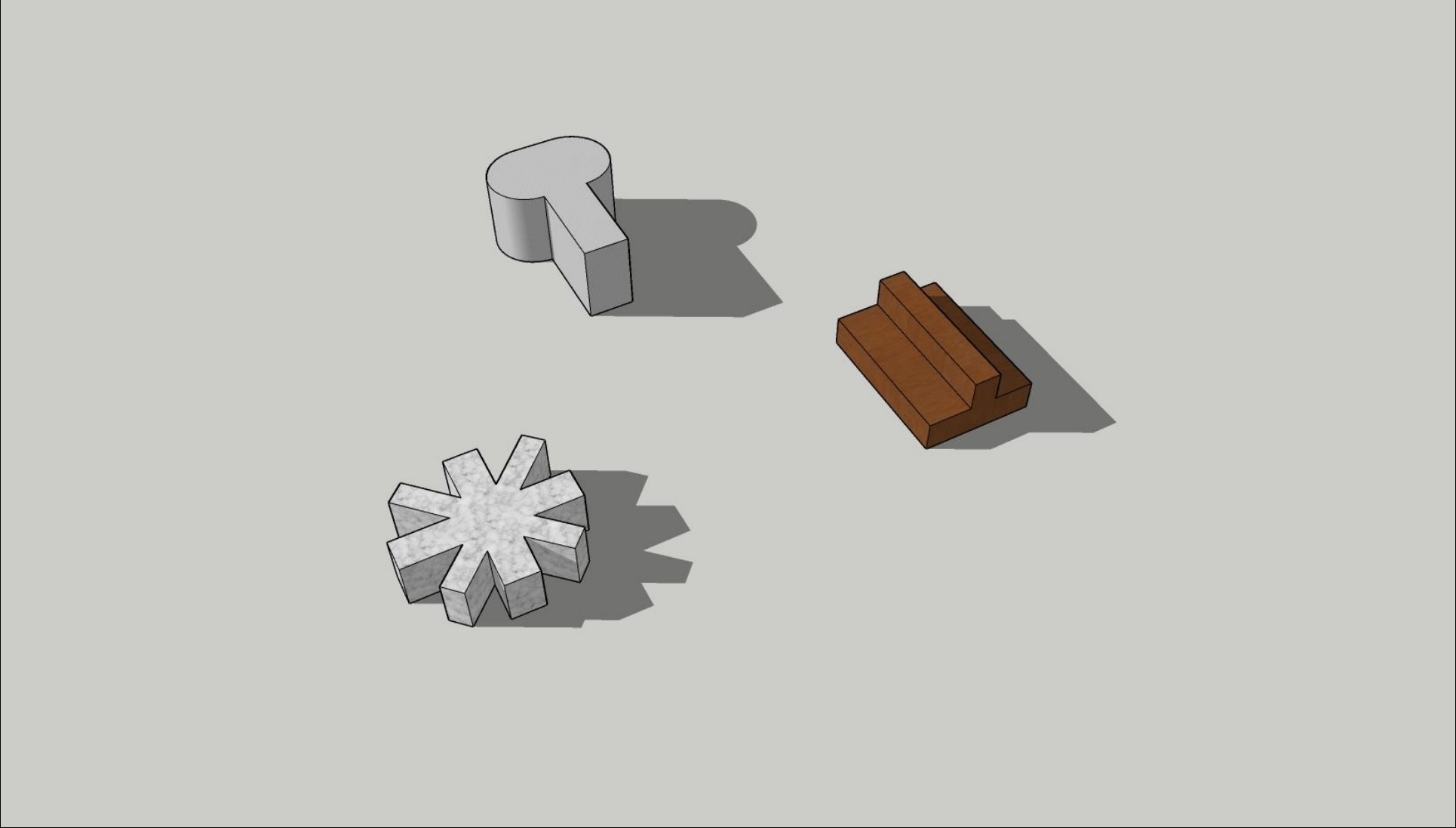

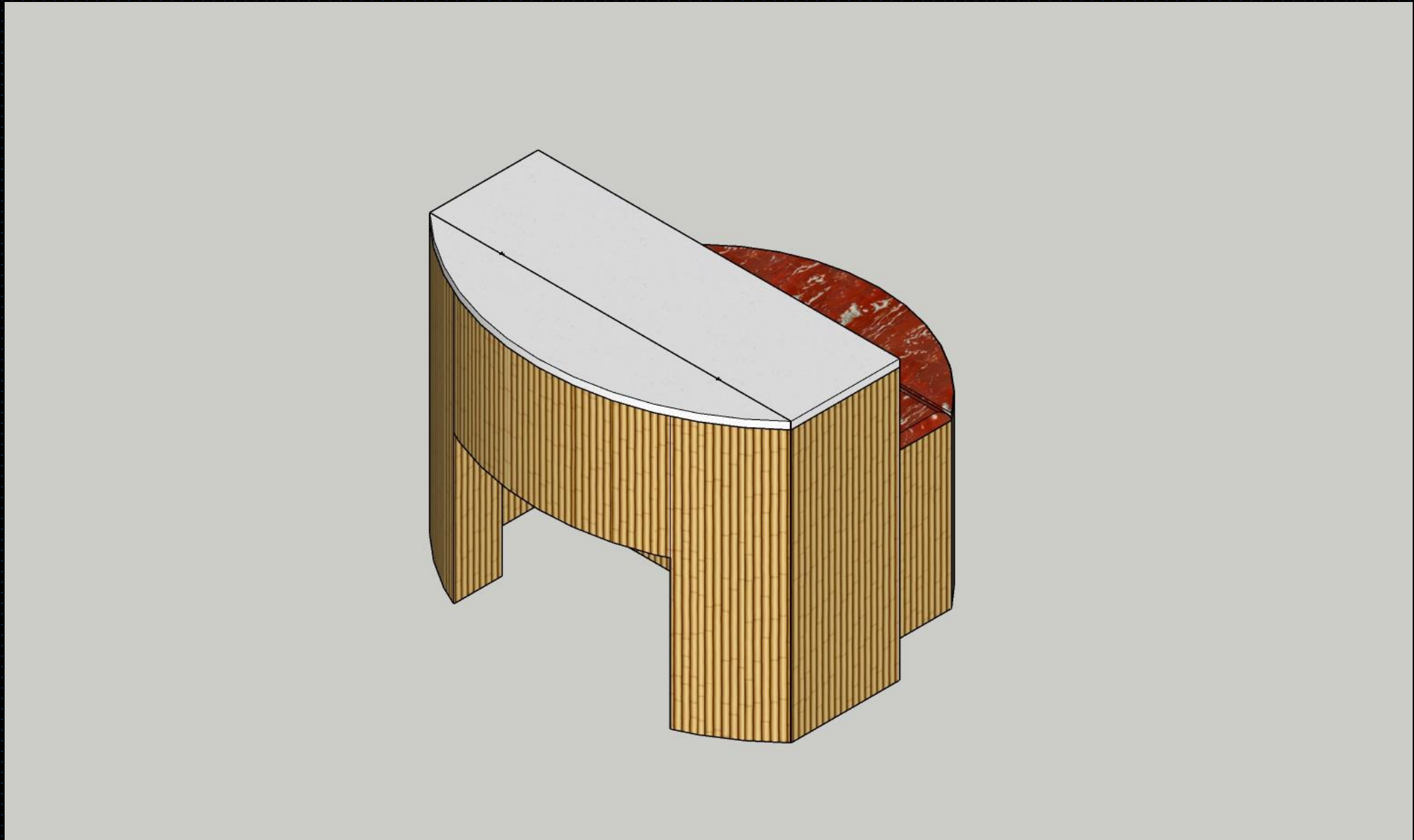

ISO VIEW



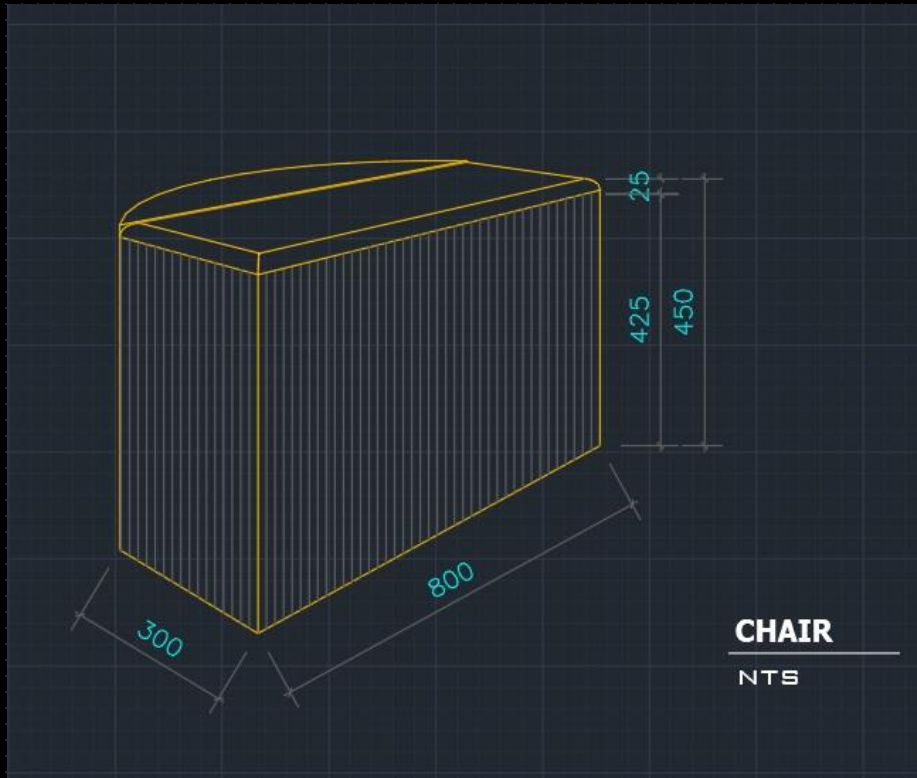
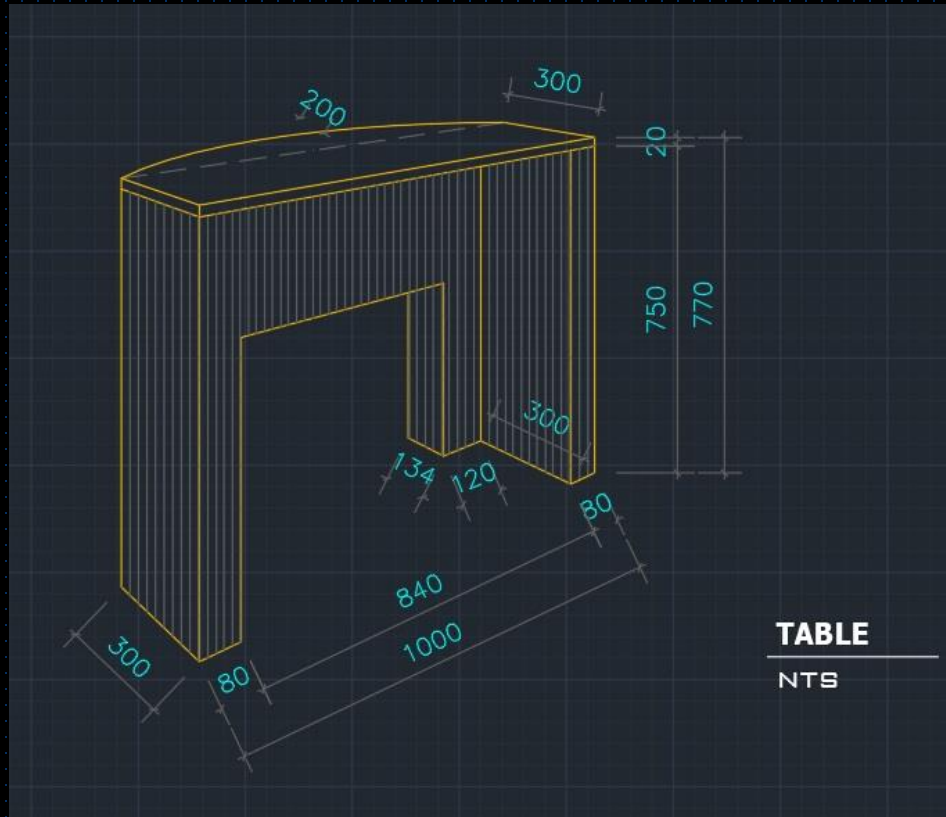
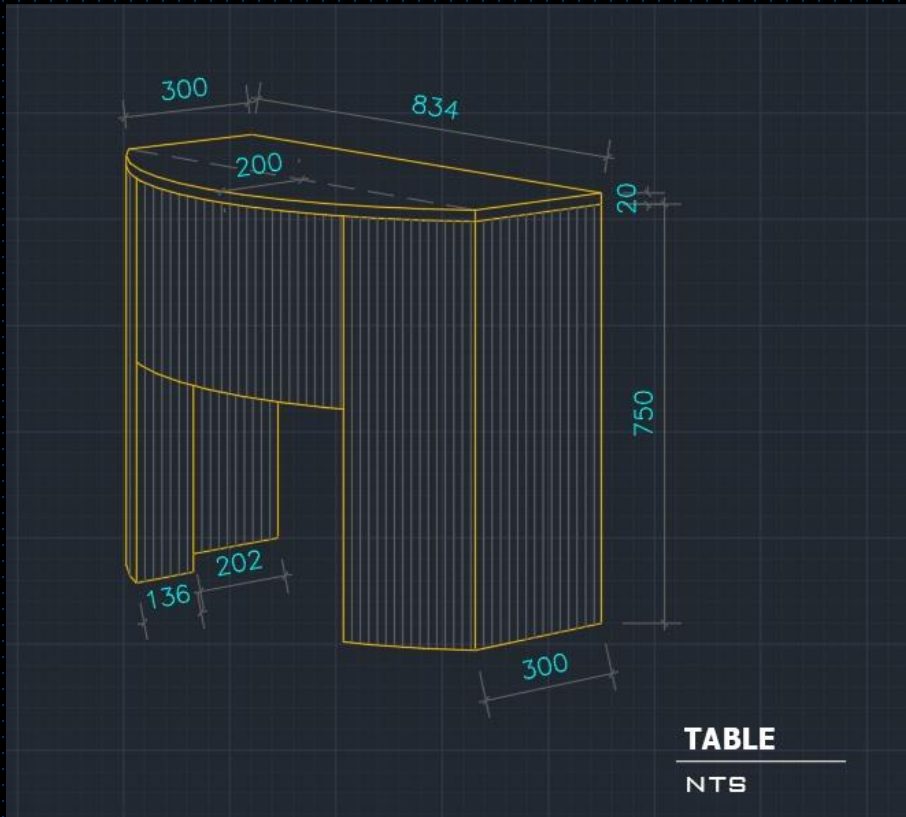

PROJECTED VIEW



PROGRESS REPORT

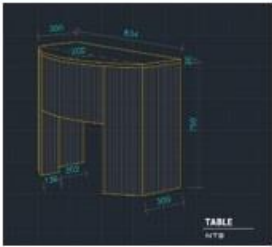
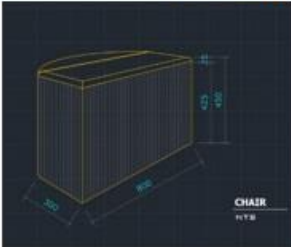

19 JULY 2021

PICTURE				
PROGRESS REPORT	COLLECTING DATA TO HEAD PRODUCTION LOOKING FOR SUPPLIER VENEER BAMBOO AT PINANGSIA			
ISSUE				
SOLUTION				

PROGRESS REPORT



3 AGUSTUS 2021

PICTURE				
PROGRESS REPORT	FOLLOW UP PRODUCTION			
ISSUE	WORKERS GET COVID 19, PRODUCTION PENDING VENEERS BAMBOO AT PIANGSIA OUT OF STOCK			
SOLUTION	PRODUCTION MOVED TO 9 AGUST LOOKING FOR NEW SUPPLIER VENEER BAMBOO AT KLENDER			



		PROGRESS REPORT			
		12 AGUSTUS 2021			
PICTURE					
PROGRESS REPORT	FOLLOW UP PRODUCTION				
ISSUE	<p>ENEERS BAMBOO AT PIANGSIA OUT OF STOCK</p> <p>LOOKING FOR SUPPLIER PUFF FOR THE CHAIR</p> <p>SEAT TOO HIGH</p>				
SOLUTION	<p>CHANGE FINISHING MATERIAL TO BAMBOO HPL</p> <p>ADJUSTMENT SEAT HIGH TO 450MM</p>				
		PROGRESS REPORT			
		13 AGUSTUS 2021			
PICTURE					
PROGRESS REPORT	FOLLOW UP PRODUCTION				
ISSUE	<p>ENEERS BAMBOO AT PIANGSIA OUT OF STOCK</p>				
SOLUTION	<p>CHANGE FINISHING MATERIAL TO BAMBOO HPL</p> <p>SEND THE FINISHING MATERIAL TO FACTORY FROM SUPPLIER</p>				

# PROGRESS REPORT

**PROGRESS REPORT  
15 AGUSTUS 2021**

<p>PICTURE</p>			
<p>PROGRESS REPORT</p>	<p>PERSIAPAN MATERIAL KOMPONEN</p>	<p>PERSIAPAN FINISHING KOMPONEN</p>	<p>PERSIAPAN TOP TABLE SOLID SURFACE</p>
<p>ISSUE</p>			
<p>SOLUTION</p>			

**PROGRESS REPORT  
18 AGUSTUS 2021**

<p>PICTURE</p>			
<p>PROGRESS REPORT</p>	<p>PERSIAPAN FINISHING KOMPONEN</p>	<p>PENEMPELAN FINISHING</p>	<p>PENEMPELAN FINISHING</p>
<p>ISSUE</p>			
<p>SOLUTION</p>			

# PROGRESS REPORT



PROGRESS REPORT  
19 AGUSTUS 2021

<p>PICTURE</p>			
<p>PROGRESS REPORT</p>	<p>PERCOBAAN DUDUK</p>	<p>PERCOBAAN DUDUK</p>	<p>PROTOTYPE 1:1 SELESAI</p>
<p>ISSUE</p>			
<p>SOLUTION</p>			

# PROGRESS REPORT





FINAL PRODUCT