

03

Senior Living

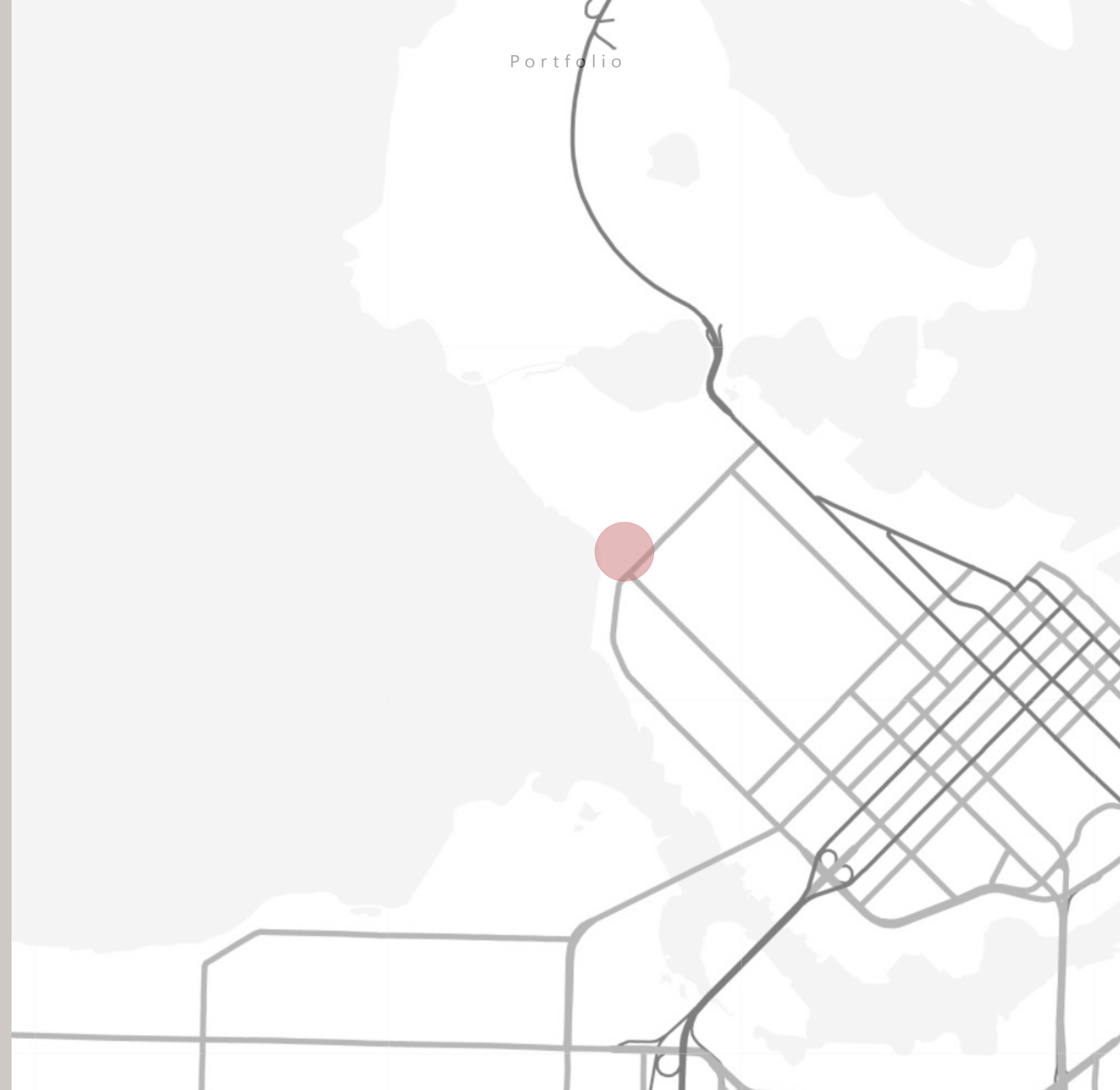

20200 56 Ave, Langley City, BC, Canada

Bubble Diagram

First Floor

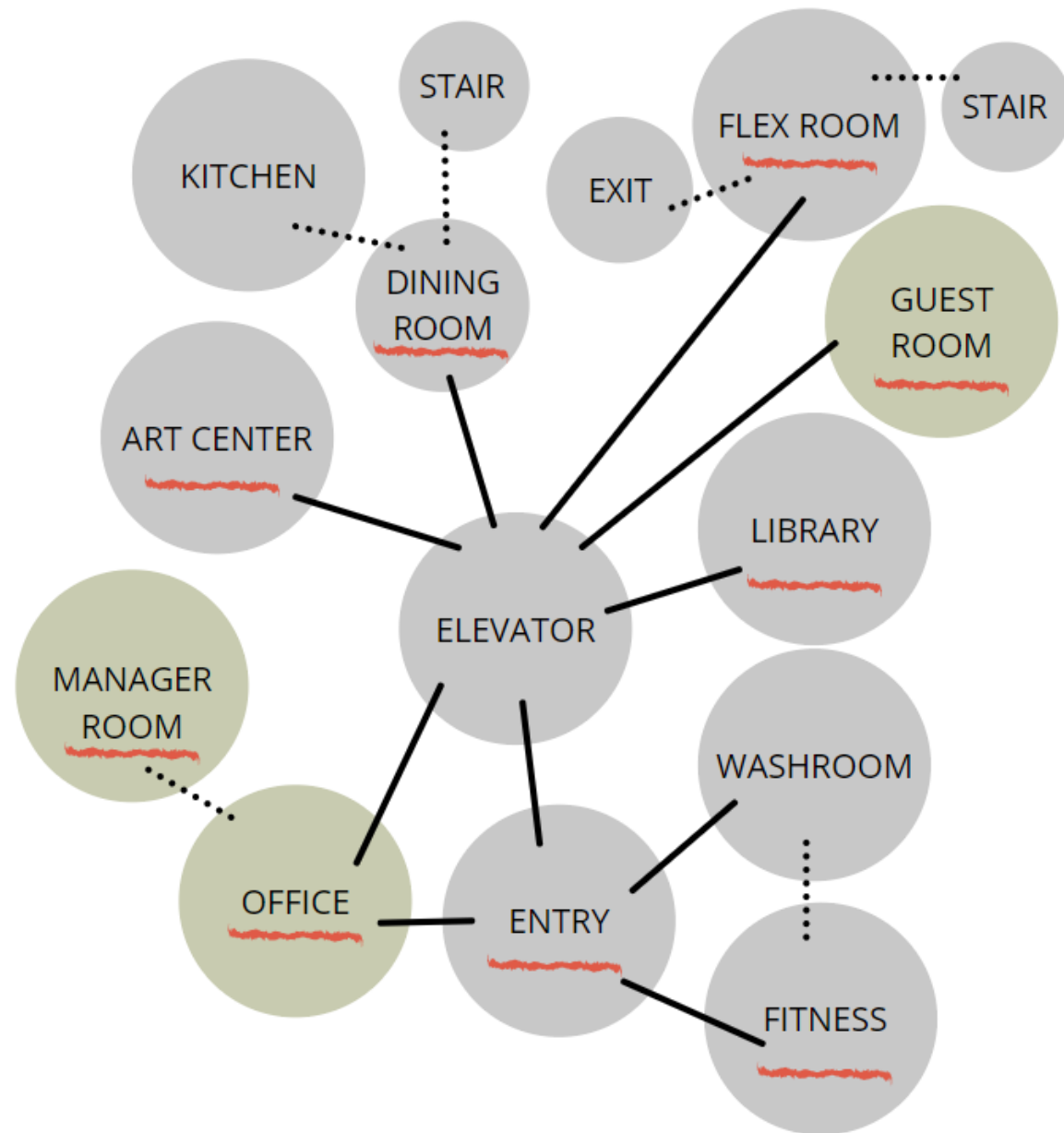

Second & Third & Fourth Floor

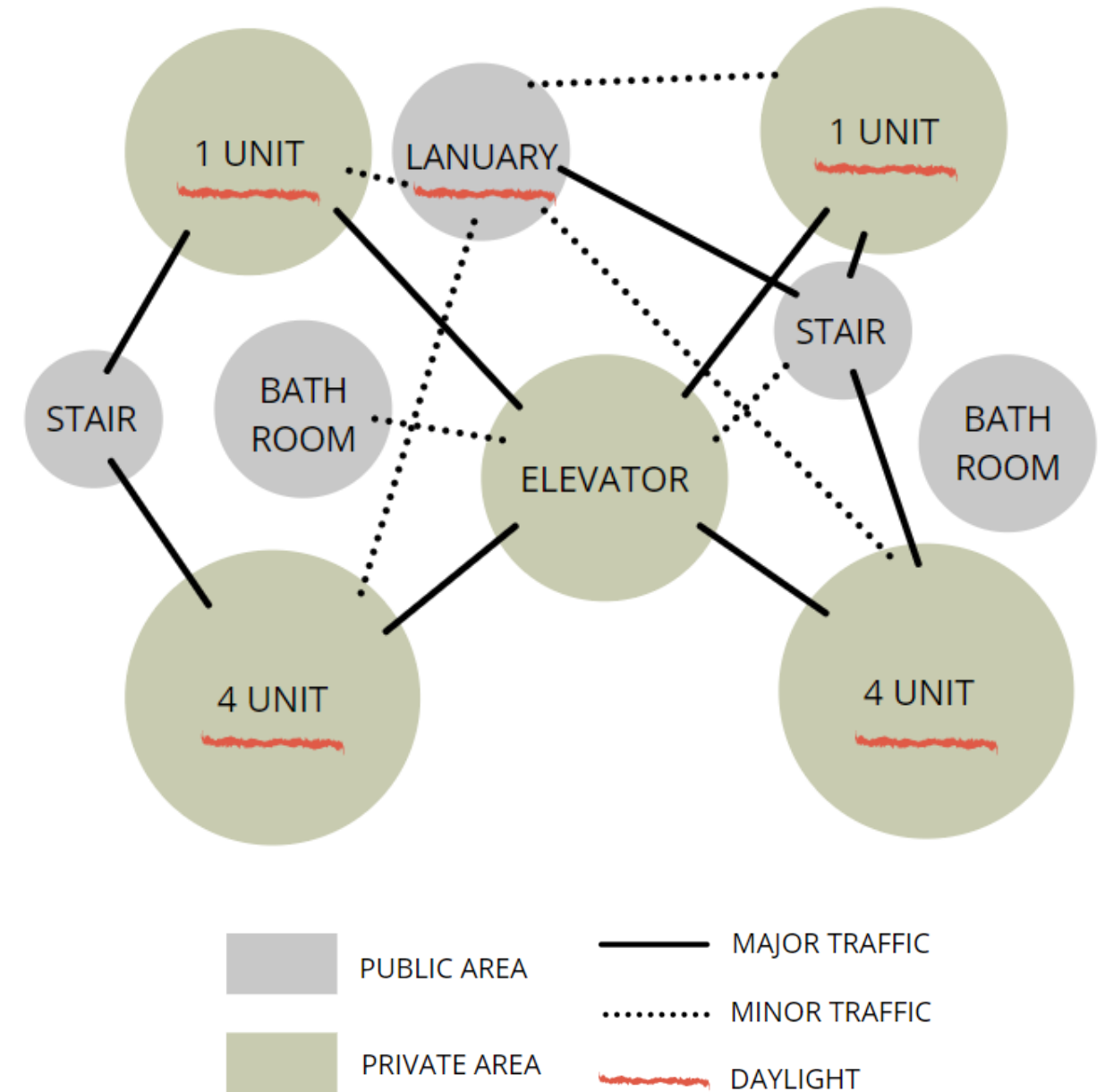

- PUBLIC AREA
- PRIVATE AREA
- MAJOR TRAFFIC
- MINOR TRAFFIC
- DAYLIGHT

Presentation Floor Plan

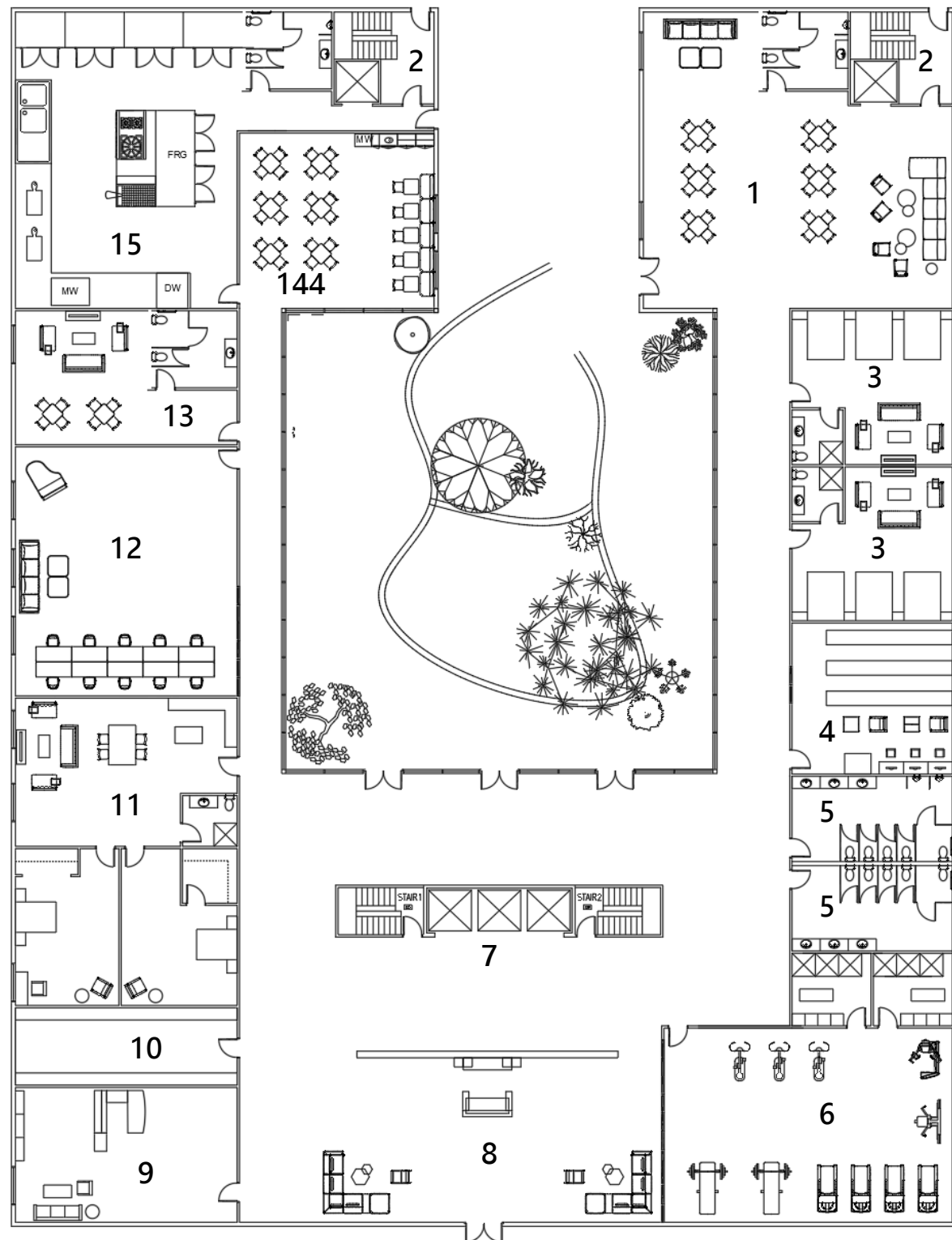

1st Floor Plan



1st Floor Rendered Plan

1. Flex Room
2. Exit
3. Guest Room
4. Library
5. Washroom
6. Fitness Room
7. Elevator
8. Reception
9. Manager Office
10. Storage
11. Manager Unit
12. Art Center
13. Staff Room
14. Dining Room
15. Kitchen

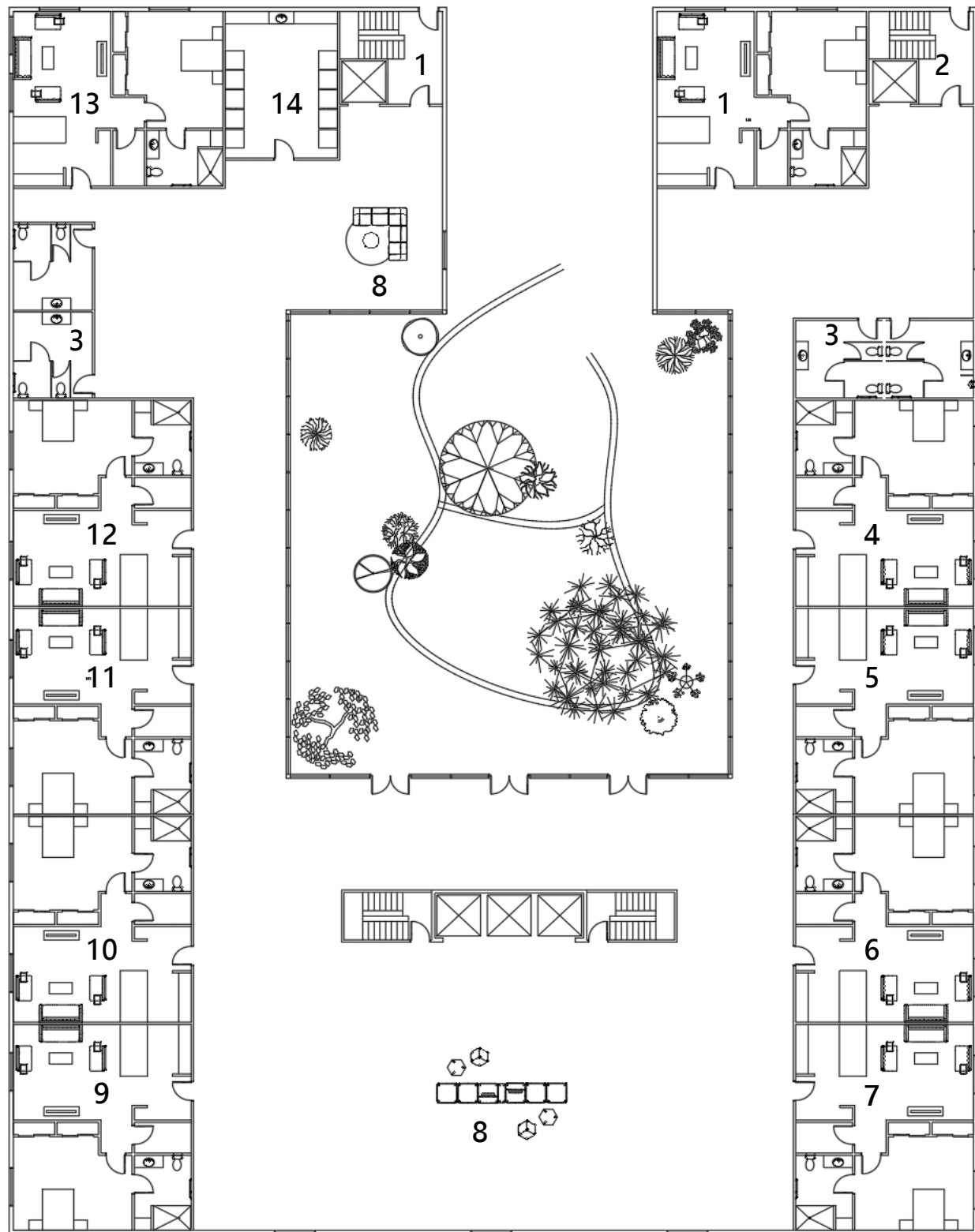

2nd-4th Floor Plan



2nd-4th Rendered Plan

- 1. Unit 1
- 2. Exit
- 3. Public Washroom
- 4. Unit 2
- 5. Unit 3
- 6. Unit 4
- 7. Unit 5
- 8. Public Area
- 9. Unit 6
- 10. Unit 7
- 11. Unit 8
- 12. Unit 9
- 13. Unit 10
- 14. Laundry Room

Unite Floor Plan

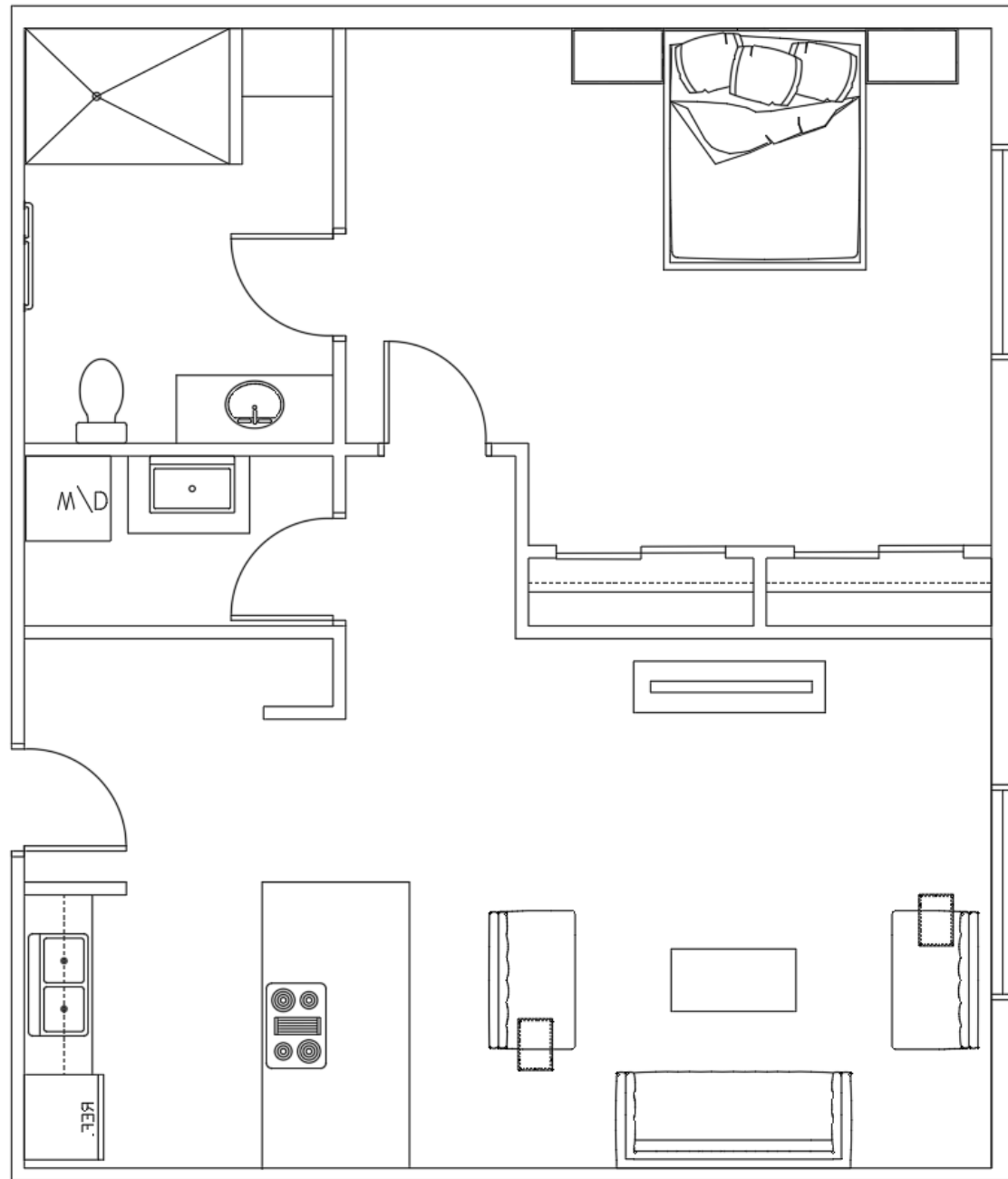

Unit 1-30 Floor Plan



Unit 1-30 Floor Plan

Materials



01



02

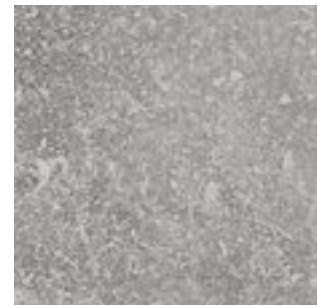

03



04



05

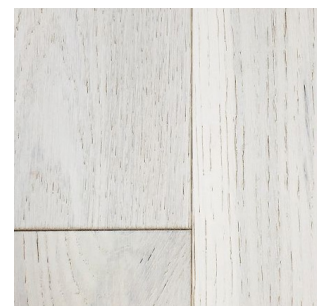

06



07



08



09



10



11

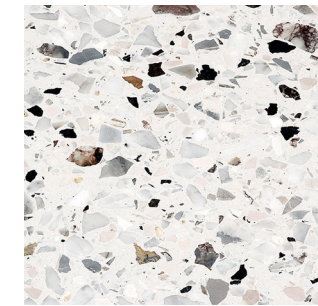

12



13

- 1. Wood Floor
- 2. Carpet Tile
- 3. Glazed Porcelain Tile
- 4. Wood Wall Panel
- 5. Glazed Porcelain Tile
- 6. Hardwood Flooring
- 7. Porcelain Tiles

- 8. Rubber Gym Floor Tile
- 9. White Painting
- 10. Mirror
- 11. Porcelain Floor Tile
- 12. Porcelain Wall Tile
- 13. Porcelain Wall Tile

Reception Desk

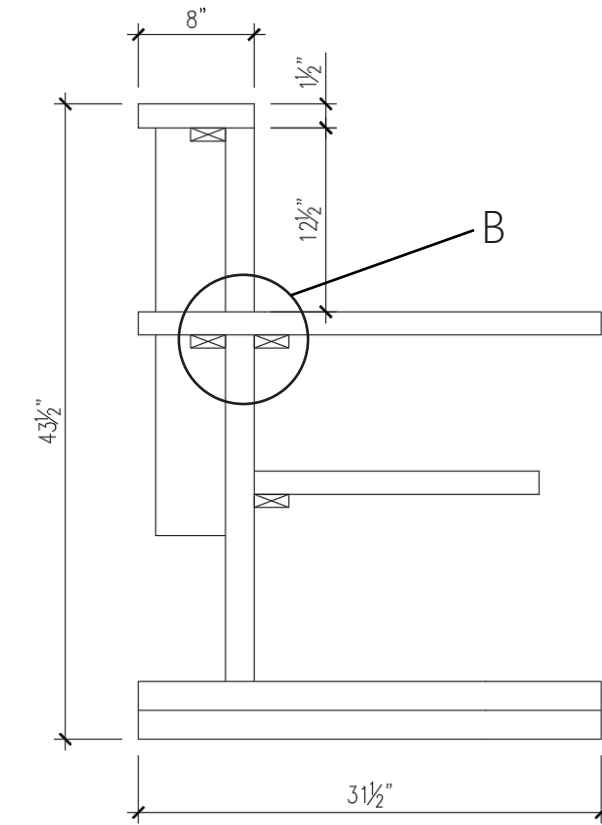

Section AA'

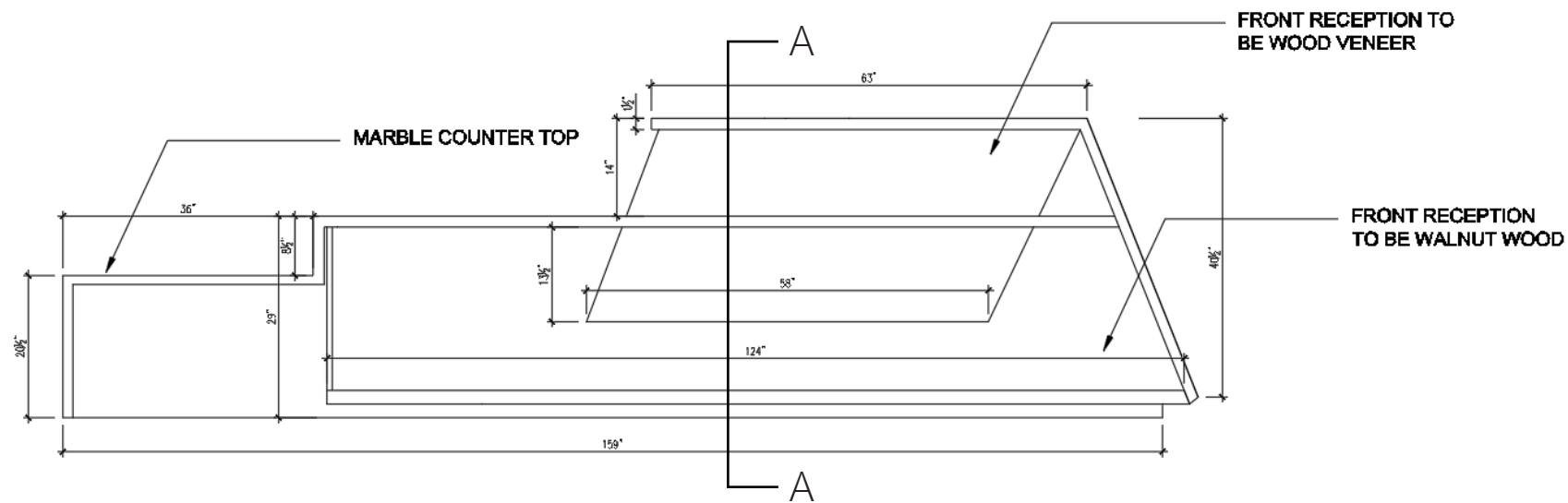

Elevation of Reception Desk

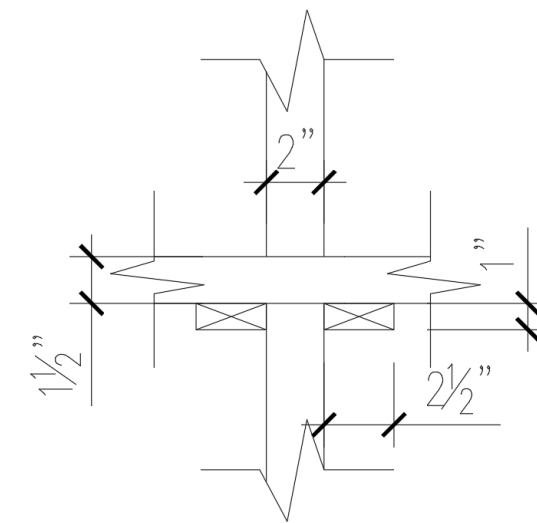

Detail B

Unit Kitchen Elevation

Unit Kitchen Section & Detail

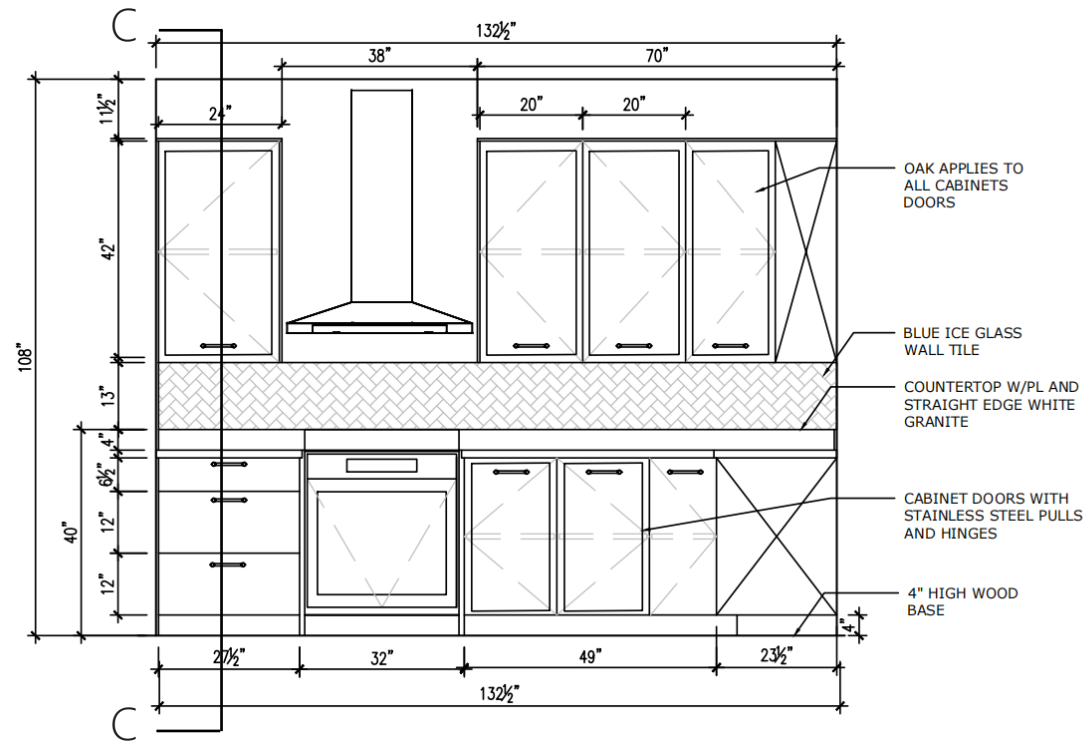

Kitchen Elevation

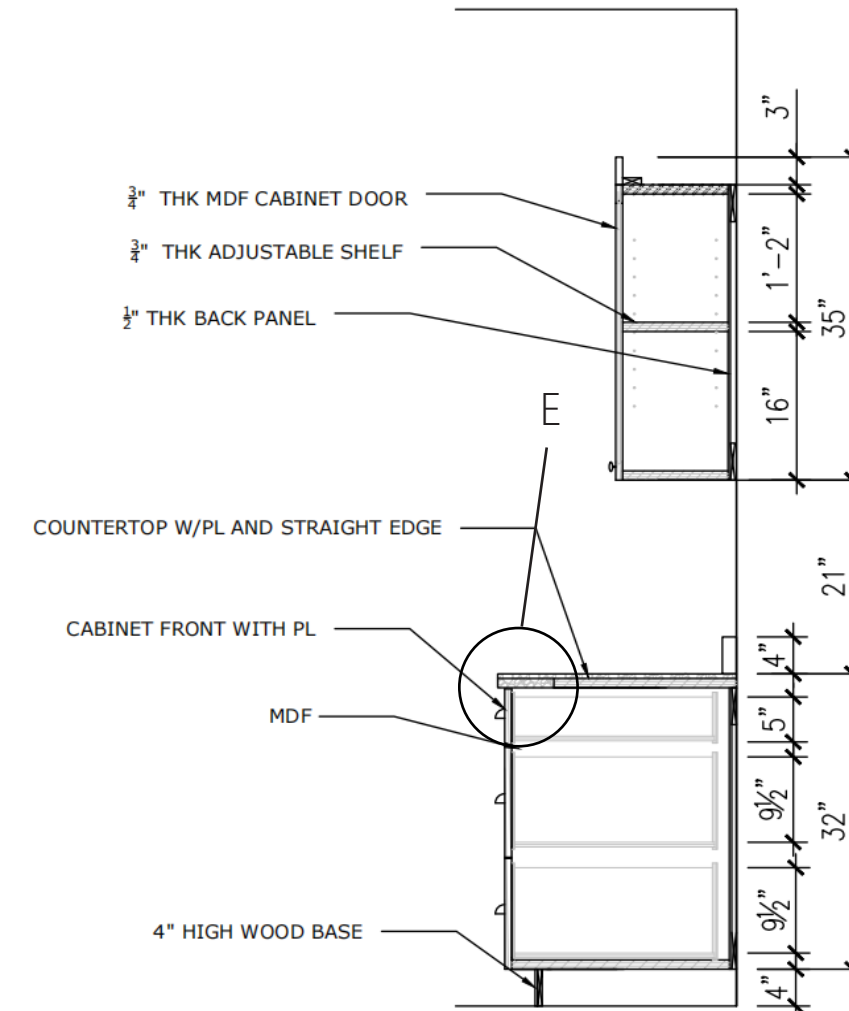

Section CC'

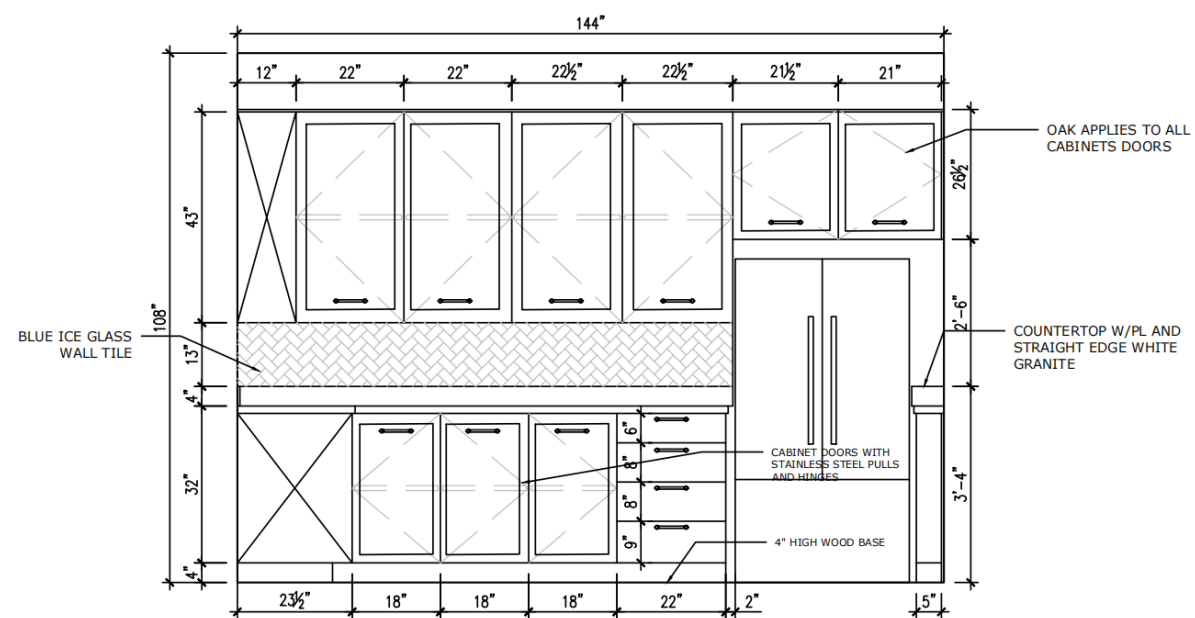

Kitchen Elevation

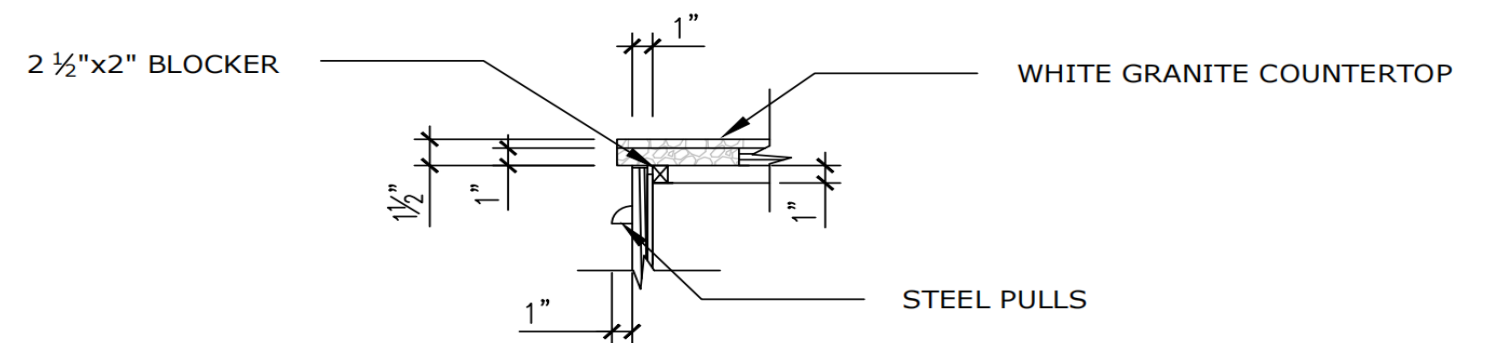

Detail EE'

Rendering



Unit Bedroom

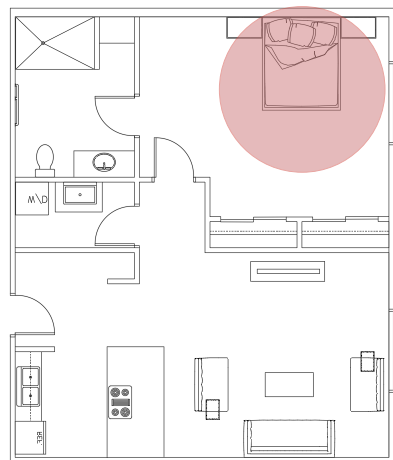

Manager Unit





Fitness Room

